

# MAYFRAN DPF DEEPBED PAPER FILTER



High filtration quality with low paper consumption

## Applications

- Short, broken metal swarf
- Turning, milling and drilling
- Suitable for all machining processes
- Machining centers and high-pressure units where space is an issue

## Avantages

- Requires very little space
- High filter fineness
- Compact design
- Integrated scratch band for effective dirt discharge
- The patent sealing function is realized with a Tsubaki chain
- Very good value for money
- Tank sizes from 400 to 2,800 l

## Dimension overview

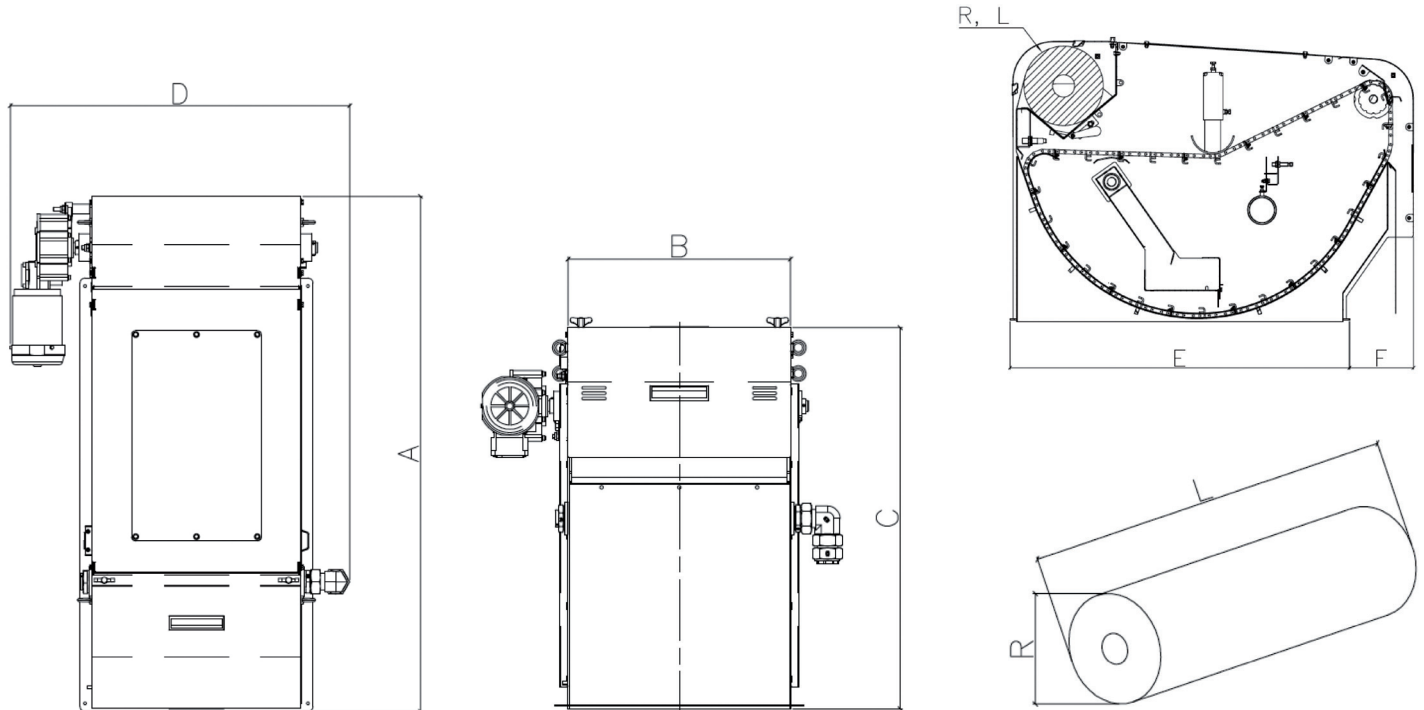

Model	Frame dimensions						Paper dimensions	
	A (mm)	B (mm)	C (mm)	D (mm)	E (mm)	F (mm)	R <sub>max</sub> (mm)	L (mm)
<b>DPF300D</b>	908	515	882	773	690	218	250	500
<b>DPF400D</b>	1278	515	882	838	1070	208	250	500
<b>DPF500D</b>	1278	715	882	1038	1070	208	250	700
<b>DPF700D</b>	1278	1015	882	1338	1070	208	250	1000

## Model overview

Model	Flow rate (l/min)	
	Emulsion 1cSt	Oil 15cSt
<b>DPF300D</b>	300	180
<b>DPF400D</b>	400	240
<b>DPF500D</b>	500	300
<b>DPF700D</b>	700	420

## Filter throughput

Model	l/min	
	Nominal	Emulsion (max)
<b>DPF300D</b>	220	280
<b>DPF400D</b>	300	370
<b>DPF500D</b>	400	460
<b>DPF700D</b>	590	650

### MAYFRAN U.K. LTD.

Unit 38 Bradley Fold Trading Estate  
Bradley Fold Road, Radcliffe,  
Bury BL2 6RT / United Kingdom  
tel.: +44 1204 36 64 69 · fax: +44 1204 36 68 40  
info@mayfran.co.uk · www.mayfran.co.uk

### MAYFRAN INTERNATIONAL B.V.

P.B. 31032, Edisonstraat 7  
6370 AA Landgraaf / Netherlands  
Tel.: +31 45 53 29-292  
info@mayfran.eu  
www.mayfran.eu